

CL60003 Automatic direction changer

Dear Customer,

with this simple and inexpensive automatic direction changing device you can let any LGB engine run on a separate track section from A to B. The electronics are designed such that it fits exactly into the LGB buffer stop (LGB # 10310). The different stop times can be set via a potentiometer and a slide switch. Two screwable insulated rail joiners with diodes and two rail connection clamps are enclosed. The maximum constant current is 5 amp.

Packing contents:

1 board with installation instructions
2 insulated rail joiners
2 rail connection clamps

Technical data:

Supply only possible with d.c. voltage!
Input: 7-24 volt = (d.c. voltage)

Note:

Please read the following description carefully before starting with the installation. **CE** Not suitable for children under the age of 14. Contains small parts. Improper use may lead to injury due to functional edges and points. Please retain these instructions!

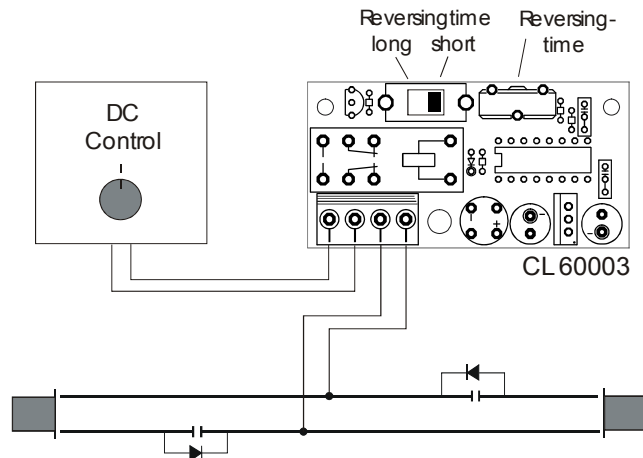
Connection:

Should you discover a fault in the fabrication despite a careful final inspection, please return this item to your dealer, together with a description of the fault and your receipt, or send the component directly to us. Any charges relating to the return of this item will have to be borne by you!

You will find our address on the packaging or on the Internet at <http://www.champex-linden.de>.

CHAMPEX-LINDEN® Modellspielwaren - Salvatorstr. 4 – D 41542 Dormagen Nievenheim
phone 02133-929877 – fax 02133-929878 - e-mail: info@champex-linden.de

© 2003 by **CHAMPEX-LINDEN®**